

D750Q8, D750QH8, D825Q8, D900Q8



- Efficient Twin Screw Air End
- Exclusive Three Year Air End Warranty
- Automatic 0 to 100% Capacity Control
- **Caterpillar Engine 3126B CAT Diesel Power**
- Side by Side Coolers
- All Components Painted Before Assembly
- Hydraulic Surge Brakes Standard
- Adjustable Height Lunette Eye
- Automatic Shutdown and Protection System
- Automatic Blowdown Valve
- Unloaded Starting / New Closed Inlet Start
- Reinforced Jack Stand
- Noise Level Limited to Maximum of 76 dBA at 7 Meters
- Standard Instrumentation
 - Panel Light*
 - Fuel Gauge*
 - Tachometer/ Hourmeter*
 - Voltmeter*
 - Discharge Air Temperature Gauge*
 - Discharge Air Pressure Gauge*
 - Engine Oil Pressure Gauge*
 - Engine Water Temperature Gauge*
 - Air/Oil Separator Maintenance Indicator*
 - Air Filter Restriction Indicator*
 - Lockable Panel Door*

DIMENSIONS

(Metrics in Parentheses)

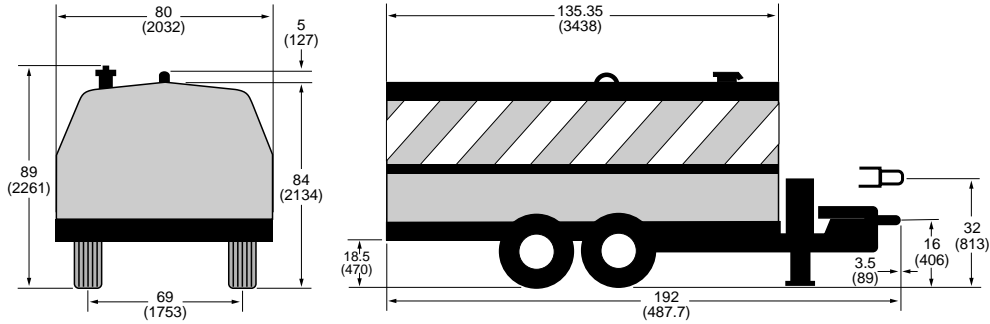

SPECIFICATIONS

(Metrics in Parentheses)

COMPRESSOR

D750Q8, D750QH8, D825Q8, D900Q8

<i>Type</i>	<i>Single stage, oil, flooded rotary screw</i>			
Ambient Oper. Temp. Range	-20° to +125°F (-29° to +52°C)			
Oil Capacity	30 gal. (114 L)			
Total Receiver Volume	11.5 ft. ³			
Air Service Connections	One 2" NPT			
Type Cooling System	Oil to Air			
Type Air Intake System	Three Stage Dry			
Type of Control	0-100% Demand			
Tire Size	9-14.5 LT 12 ply rating			
Weight, Serviced	8500 lbs. (3855 Kg)			
Rated Delivery	D750Q8 750 cfm (21.2 m ³ /min)	D750QH8 750 cfm (21.2 m ³ /min)	D825Q8 825 cfm (23.3 m ³ /min)	D900Q8 900 cfm (26.4 m ³ /min)
Rated Operating Pressure	100 PSIG (794 kPa)	150 PSIG (1035 kPa)	125 PSIG (862 kPa)	100 PSIG (794 kPa)
Operating Pressure Range	70-115 PSIG	70-150 PSIG	70-125 PSIG	70-115 PSIG

ENGINE

D750Q8, D750QH8, D825Q8, D900Q8

<i>Type</i>	<i>Diesel</i>			
Make	Caterpillar			
Model	3126B			
Number of Cylinders	6			
Bore and Stroke	4.33" x 5" (110 x 127 mm)			
Displacement	442 in ³ (7.2 L)			
Total Oil Capacity	7.5 gals. (28 L)			
Cooling System Capacity	42 qts. (40 L)			
Battery Rating	24 Volts			
CCA @ 0°F	1150 Amps per Battery			
Idle Speed	1400 RPM			
Fuel Tank Capacity	90 gal. (340.7 L)			
Horsepower @ rated RPM	D750Q8 259 (193 kw)	D750QH8 259 (193 kw)	D825Q8 271 (202 kw)	D900Q8 275 (205 kw)
Full Load Speed	1800 RPM	1800 RPM	2000 RPM	2200 RPM

***OTHER MODELS
AVAILABLE**